

CYPRESS AVENUE

CLARAVALE STAGE 5A

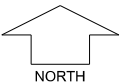

SCALE 1:250

MNG, Ref: 105952lip-024d Date: 28/05/2026
Depicted information subject to approvals and survey.
 All dimensions and areas are subject to survey. The particulars on this brochure are supplied for Information only and shall not be taken as a representation in any respect on the part of the Vendor or its agent. Authorities should be consulted when services are contained within lot boundaries as building restrictions may apply. All retaining walls and associated easements are shown exaggerated for clarity.

LEGEND

- WATER
- WATER METER
- WATER HYDRANT
- WATER VALVE
- DRAINAGE
- STORMWATER CONNECTION PIT & EASEMENT
- RETAINING WALL & HEIGHT
- POWER DOME MINI PILLAR
- POWER DOME UNIVERSAL PILLAR
- STREETLIGHTS
- TRANSFORMER SITE WITH FIRE COVENANT
- TRANSFORMER SITE WITH NOISE ZONE
- PREFERRED GARAGE LOCATION REFER LDP
- TOP OF KERB HEIGHT
- SPOT LEVEL
- PAD LEVEL
- ROAD LEVEL
- OPTICOMM CONNECTION
- OPTICOMM CABINET
- SEWER / MANHOLE
- BUSHFIRE ATTACK LEVEL

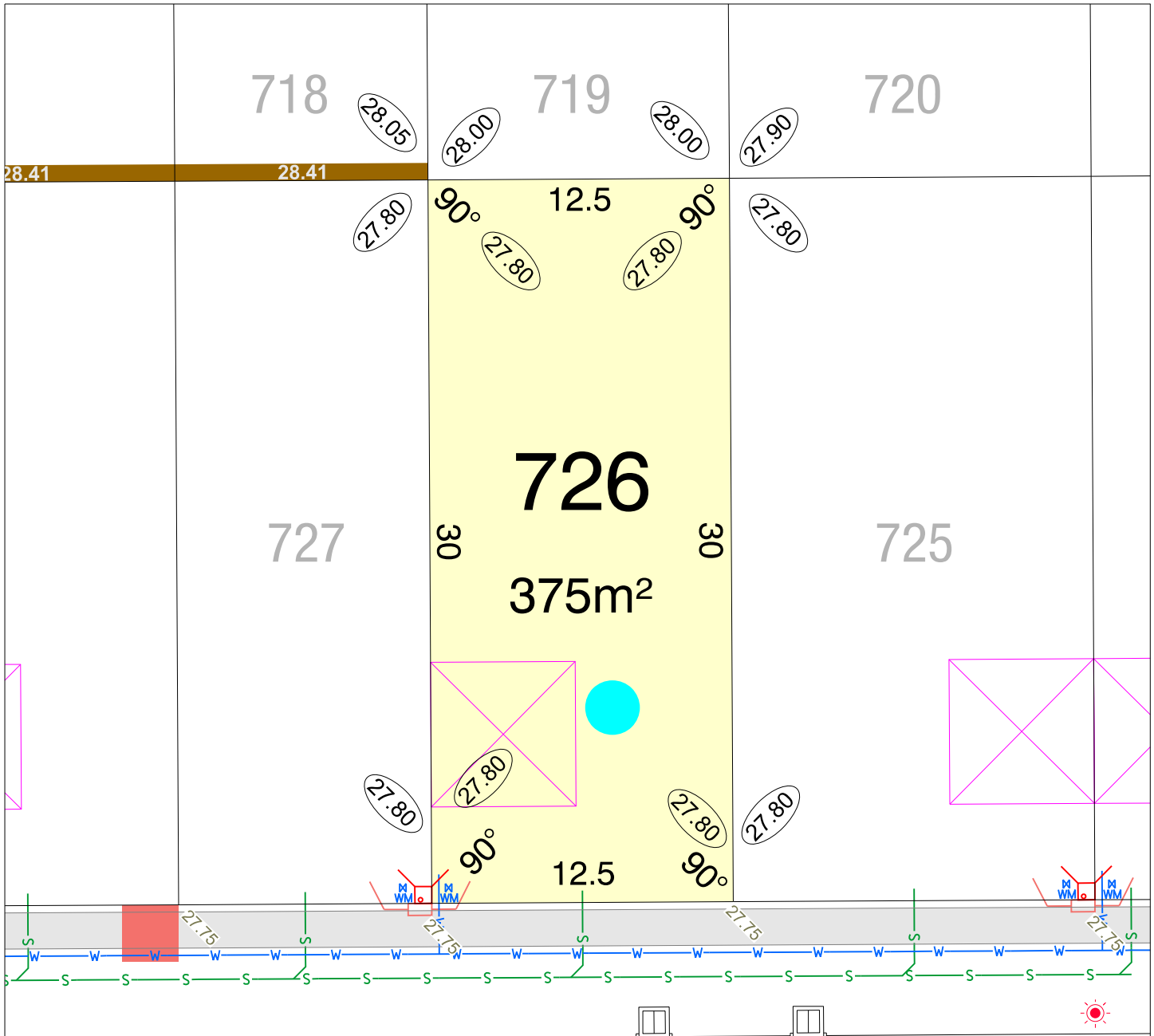

CYPRESS AVENUE

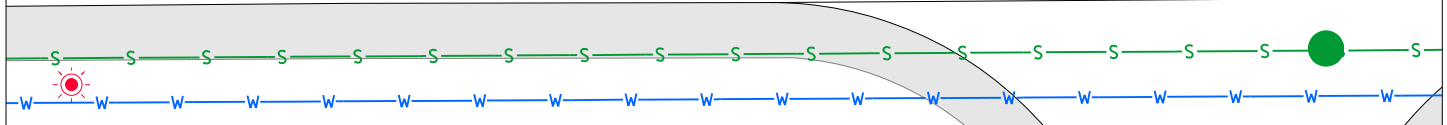

CLARAVALE STAGE 5A

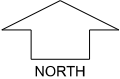

SCALE 1:250

MNG, Ref: 105952lip-024d Date: 28/05/2026
Depicted information subject to approvals and survey.
 All dimensions and areas are subject to survey. The particulars on this brochure are supplied for Information only and shall not be taken as a representation in any respect on the part of the Vendor or its agent. Authorities should be consulted when services are contained within lot boundaries as building restrictions may apply. All retaining walls and associated easements are shown exaggerated for clarity.

LEGEND

- WATER
- WATER METER
- WATER HYDRANT
- WATER VALVE
- DRAINAGE
- STORMWATER CONNECTION PIT & EASEMENT
- RETAINING WALL & HEIGHT
- POWER DOME MINI PILLAR
- POWER DOME UNIVERSAL PILLAR
- STREETLIGHTS
- TRANSFORMER SITE WITH FIRE COVENANT
- TRANSFORMER SITE WITH NOISE ZONE
- PREFERRED GARAGE LOCATION REFER LDP
- TOP OF KERB HEIGHT
- SPOT LEVEL
- PAD LEVEL
- ROAD LEVEL
- OPTICOMM CONNECTION
- OPTICOMM CABINET
- SEWER / MANHOLE
- BUSHFIRE ATTACK LEVEL

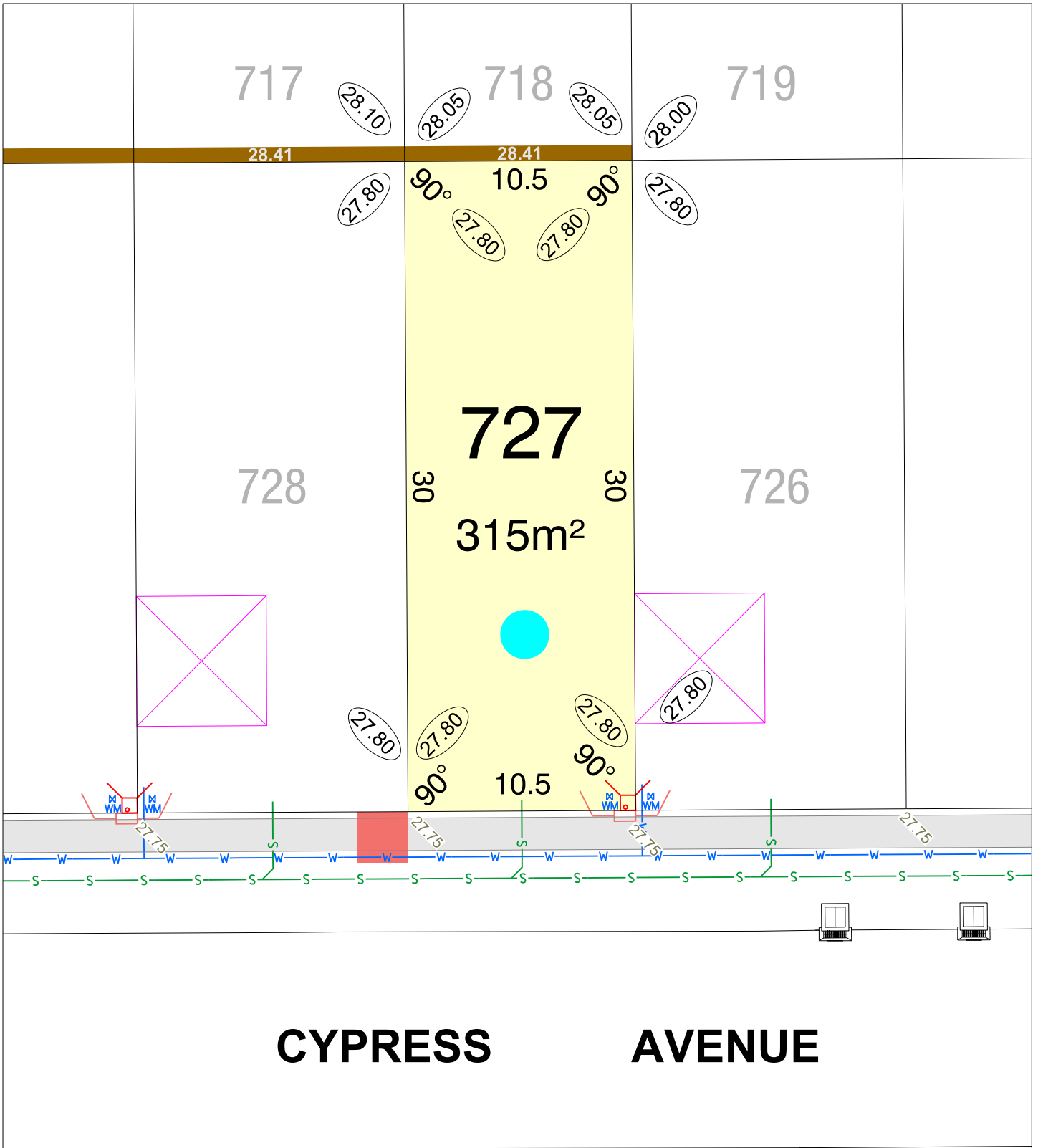

**CLARAVALE
STAGE 5A**

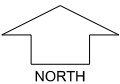

SCALE 1:250

MNG. Ref: 105952lip-024d Date: 28/05/2026
 Depicted information subject to approvals and survey.
 All dimensions and areas are subject to survey. The particulars on this brochure are supplied for Information only and shall not be taken as a representation in any respect on the part of the Vendor or its agent. Authorities should be consulted when services are contained within lot boundaries as building restrictions may apply. All retaining walls and associated easements are shown exaggerated for clarity.

LEGEND

- WATER
- WATER METER
- WATER HYDRANT
- WATER VALVE
- DRAINAGE
- STORMWATER CONNECTION PIT & EASEMENT
- RETAINING WALL & HEIGHT
- POWER DOME MINI PILLAR
- POWER DOME UNIVERSAL PILLAR
- STREETLIGHTS
- TRANSFORMER SITE WITH FIRE COVENANT
- TRANSFORMER SITE WITH NOISE ZONE
- PREFERRED GARAGE LOCATION REFER LDP
- TOP OF KERB HEIGHT
- SPOT LEVEL
- PAD LEVEL
- ROAD LEVEL
- OPTICOMM CONNECTION
- OPTICOMM CABINET
- SEWER / MANHOLE
- BUSHFIRE ATTACK LEVEL

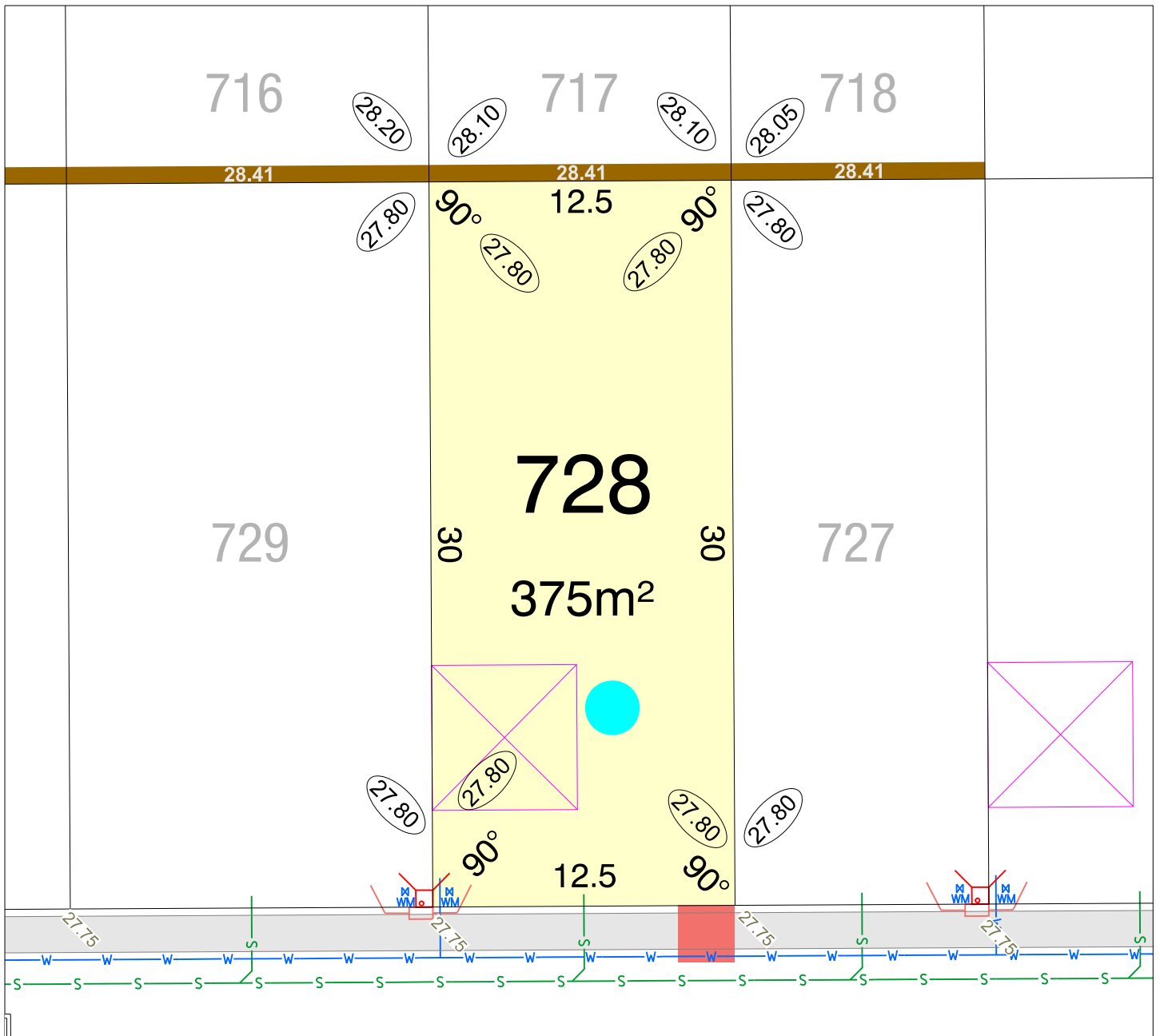

CYPRESS AVENUE

CLARAVALE STAGE 5A

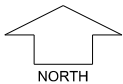

SCALE 1:250

MNG, Ref: 105952lip-024d Date: 28/05/2026
 Depicted information subject to approvals and survey.
 All dimensions and areas are subject to survey. The particulars on this brochure are supplied for Information only and shall not be taken as a representation in any respect on the part of the Vendor or its agent. Authorities should be consulted when services are contained within lot boundaries as building restrictions may apply. All retaining walls and associated easements are shown exaggerated for clarity.

LEGEND

- WATER
- WATER METER
- WATER HYDRANT
- WATER VALVE
- DRAINAGE
- STORMWATER CONNECTION PIT & EASEMENT
- RETAINING WALL & HEIGHT
- POWER DOME MINI PILLAR
- POWER DOME UNIVERSAL PILLAR
- STREETLIGHTS
- TRANSFORMER SITE WITH FIRE COVENANT
- TRANSFORMER SITE WITH NOISE ZONE
- PREFERRED GARAGE LOCATION REFER LDP
- TOP OF KERB HEIGHT
- SPOT LEVEL
- PAD LEVEL
- ROAD LEVEL
- OPTICOMM CONNECTION
- OPTICOMM CABINET
- SEWER / MANHOLE
- BUSHFIRE ATTACK LEVEL

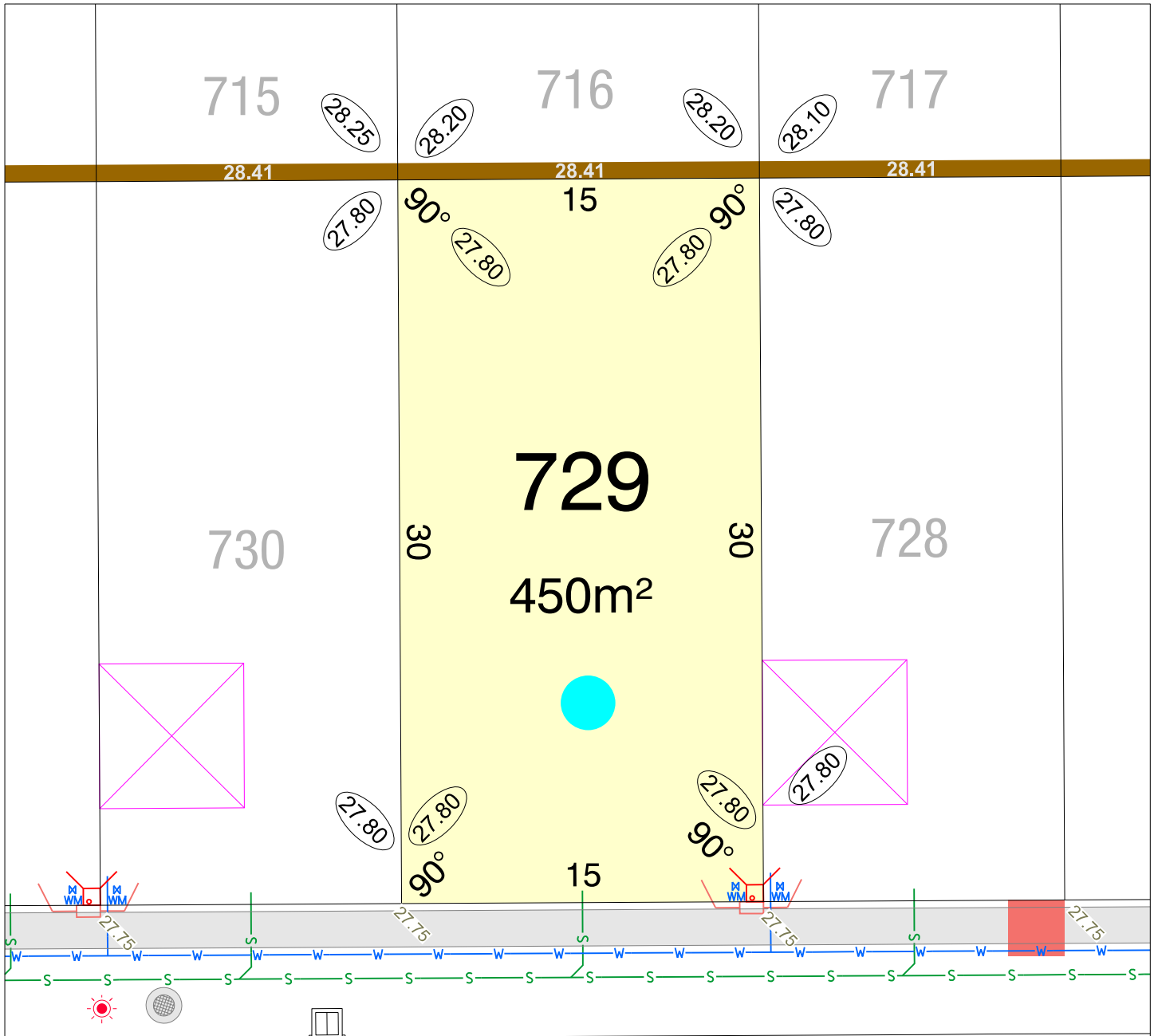

CYPRESS AVENUE

CLARAVALE STAGE 5A

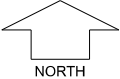

SCALE 1:250

MNG, Ref: 105952lip-024d Date: 28/05/2026
Depicted information subject to approvals and survey.
 All dimensions and areas are subject to survey. The particulars on this brochure are supplied for Information only and shall not be taken as a representation in any respect on the part of the Vendor or its agent. Authorities should be consulted when services are contained within lot boundaries as building restrictions may apply. All retaining walls and associated easements are shown exaggerated for clarity.

LEGEND

- | | | |
|--------------------------------------|-------------------------------------|-----------------------|
| WATER | POWER DOME MINI PILLAR | TOP OF KERB HEIGHT |
| WATER METER | POWER DOME UNIVERSAL PILLAR | SPOT LEVEL |
| WATER HYDRANT | STREETLIGHTS | PAD LEVEL |
| WATER VALVE | TRANSFORMER SITE WITH FIRE COVENANT | ROAD LEVEL |
| DRAINAGE | TRANSFORMER SITE WITH NOISE ZONE | OPTICOMM CONNECTION |
| STORMWATER CONNECTION PIT & EASEMENT | PREFERRED GARAGE LOCATION REFER LDP | OPTICOMM CABINET |
| RETAINING WALL & HEIGHT | | SEWER / MANHOLE |
| | | BUSHFIRE ATTACK LEVEL |

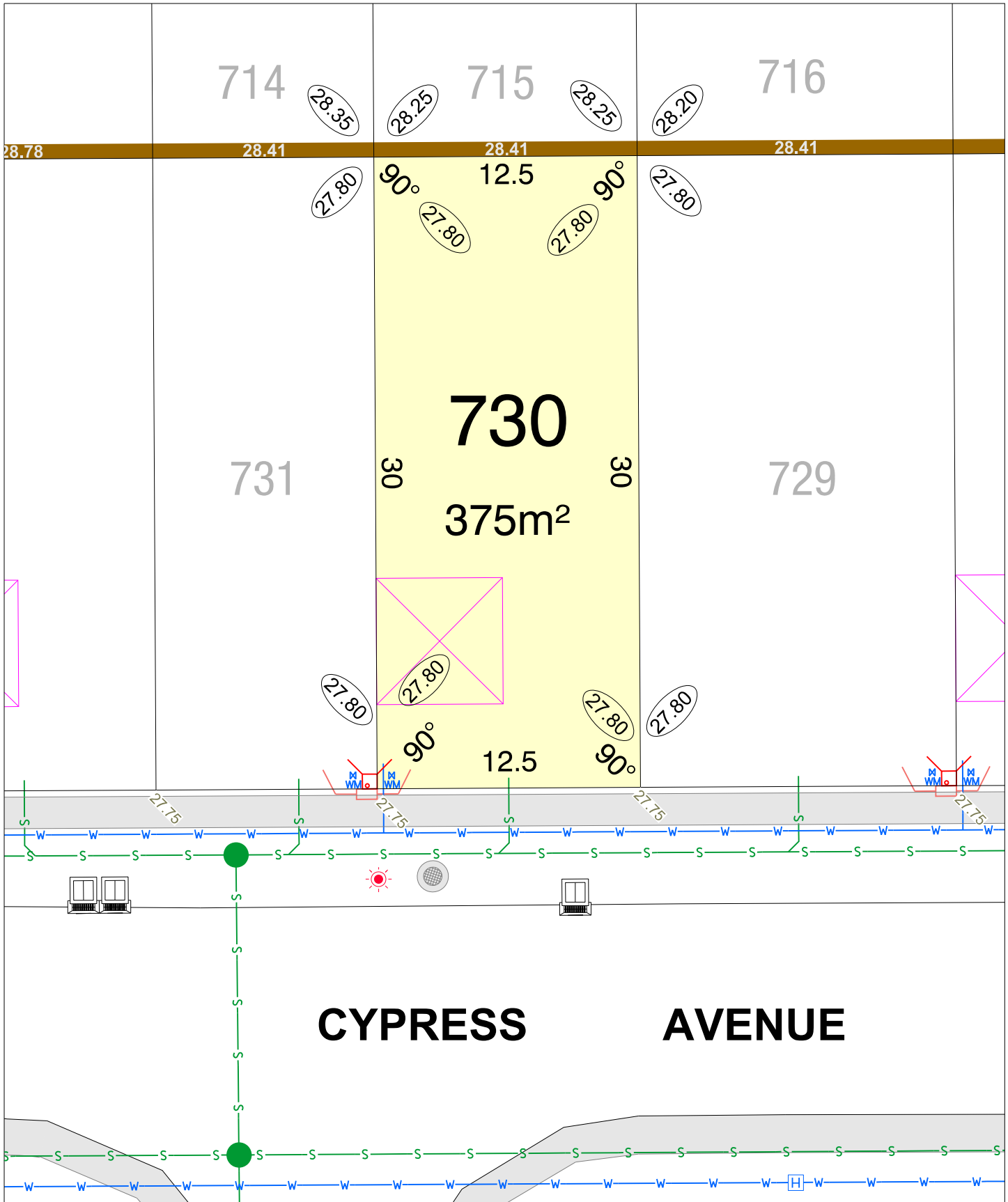

CLARAVALE STAGE 5A

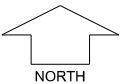

SCALE 1:250

MNG, Ref: 105952lip-024d Date: 28/05/2026
Depicted information subject to approvals and survey.
 All dimensions and areas are subject to survey. The particulars on this brochure are supplied for Information only and shall not be taken as a representation in any respect on the part of the Vendor or its agent. Authorities should be consulted when services are contained within lot boundaries as building restrictions may apply. All retaining walls and associated easements are shown exaggerated for clarity.

LEGEND

- WATER
- WATER METER
- WATER HYDRANT
- WATER VALVE
- DRAINAGE
- STORMWATER CONNECTION PIT & EASEMENT
- RETAINING WALL & HEIGHT
- POWER DOME MINI PILLAR
- POWER DOME UNIVERSAL PILLAR
- STREETLIGHTS
- TRANSFORMER SITE WITH FIRE COVENANT
- TRANSFORMER SITE WITH NOISE ZONE
- PREFERRED GARAGE LOCATION REFER LDP
- TOP OF KERB HEIGHT
- SPOT LEVEL
- PAD LEVEL
- ROAD LEVEL
- OPTICOMM CONNECTION
- OPTICOMM CABINET
- SEWER / MANHOLE
- BUSHFIRE ATTACK LEVEL

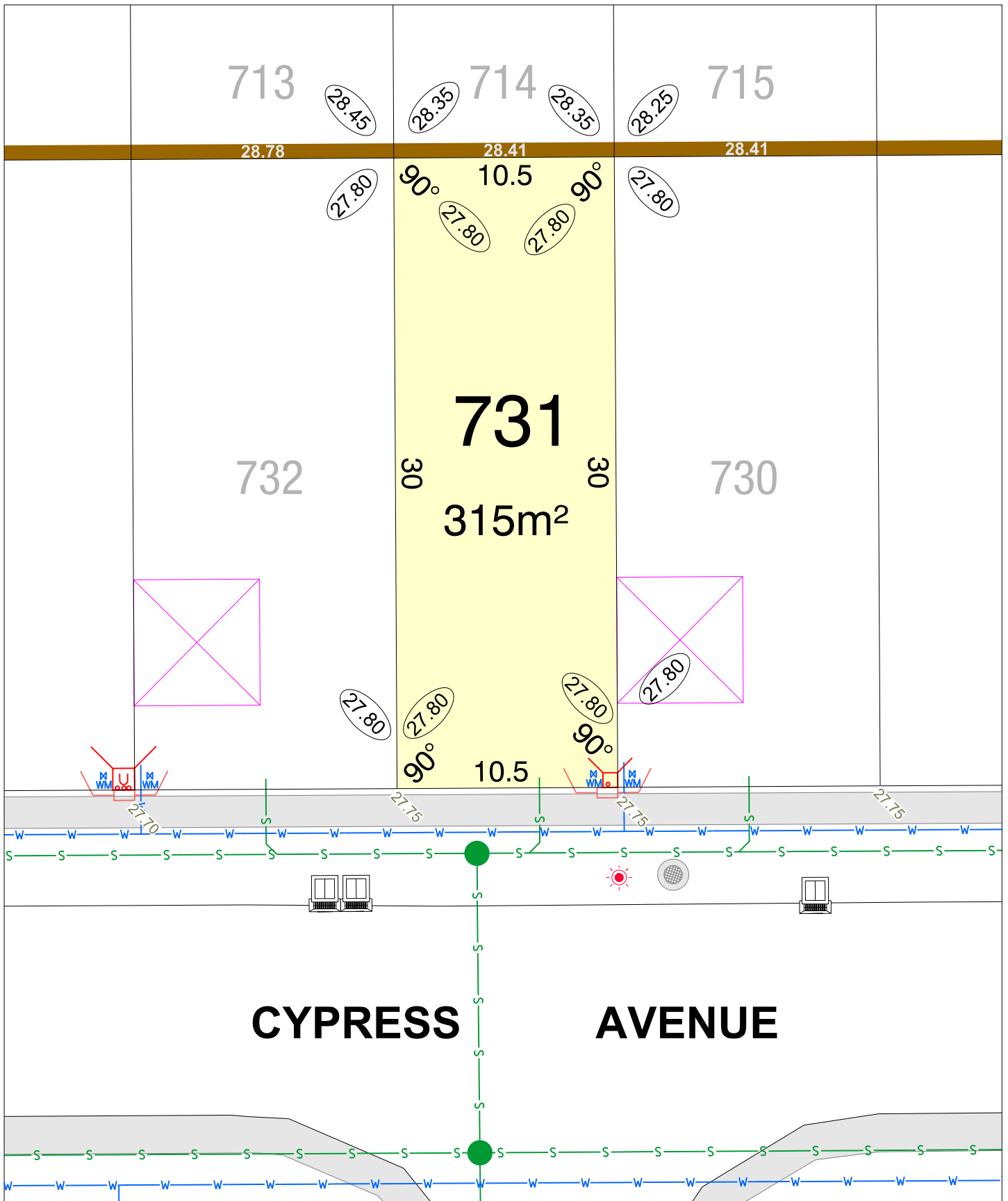

CLARAVALE STAGE 5A

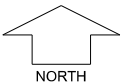

SCALE 1:250

MNG, Ref: 105952lip-024d Date: 28/05/2026
Depicted information subject to approvals and survey.
 All dimensions and areas are subject to survey. The particulars on this brochure are supplied for Information only and shall not be taken as a representation in any respect on the part of the Vendor or its agent. Authorities should be consulted when services are contained within lot boundaries as building restrictions may apply. All retaining walls and associated easements are shown exaggerated for clarity.

LEGEND

- | | | |
|--------------------------------------|-------------------------------------|-----------------------|
| WATER | POWER DOME MINI PILLAR | TOP OF KERB HEIGHT |
| WATER METER | POWER DOME UNIVERSAL PILLAR | SPOT LEVEL |
| WATER HYDRANT | STREETLIGHTS | PAD LEVEL |
| WATER VALVE | TRANSFORMER SITE WITH FIRE COVENANT | ROAD LEVEL |
| DRAINAGE | TRANSFORMER SITE WITH NOISE ZONE | OPTICOMM CONNECTION |
| STORMWATER CONNECTION PIT & EASEMENT | PREFERRED GARAGE LOCATION REFER LDP | OPTICOMM CABINET |
| RETAINING WALL & HEIGHT | | SEWER / MANHOLE |
| | | BUSHFIRE ATTACK LEVEL |

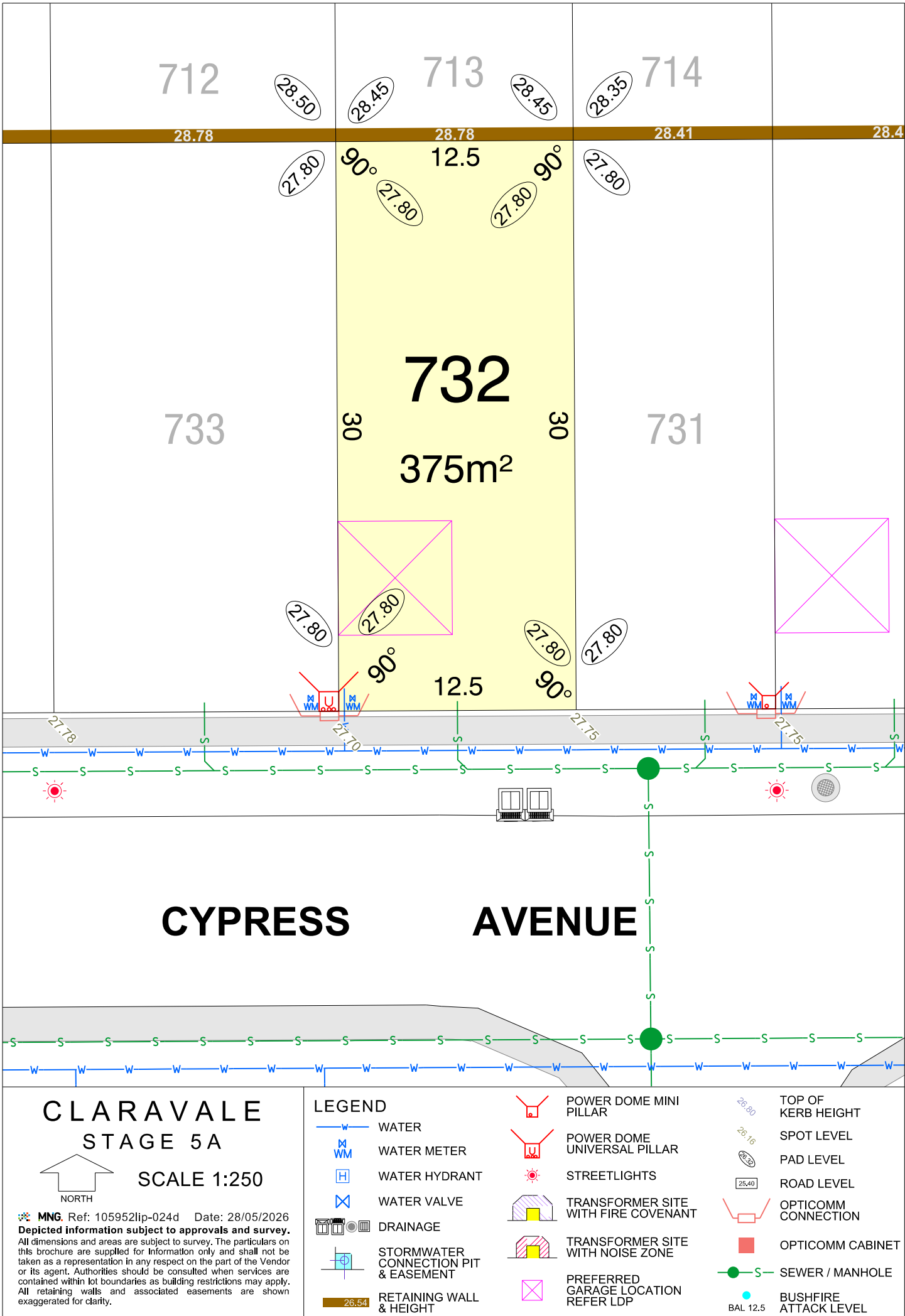

CLARAVALE STAGE 5A

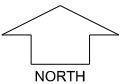

SCALE 1:250

MNG, Ref: 105952lip-024d Date: 28/05/2026
Depicted information subject to approvals and survey.
 All dimensions and areas are subject to survey. The particulars on this brochure are supplied for Information only and shall not be taken as a representation in any respect on the part of the Vendor or its agent. Authorities should be consulted when services are contained within lot boundaries as building restrictions may apply. All retaining walls and associated easements are shown exaggerated for clarity.

LEGEND

- WATER
- WATER METER
- WATER HYDRANT
- WATER VALVE
- DRAINAGE
- STORMWATER CONNECTION PIT & EASEMENT
- RETAINING WALL & HEIGHT
- POWER DOME MINI PILLAR
- POWER DOME UNIVERSAL PILLAR
- STREETLIGHTS
- TRANSFORMER SITE WITH FIRE COVENANT
- TRANSFORMER SITE WITH NOISE ZONE
- PREFERRED GARAGE LOCATION REFER LDP
- TOP OF KERB HEIGHT
- SPOT LEVEL
- PAD LEVEL
- ROAD LEVEL
- OPTICOMM CONNECTION
- OPTICOMM CABINET
- SEWER / MANHOLE
- BUSHFIRE ATTACK LEVEL

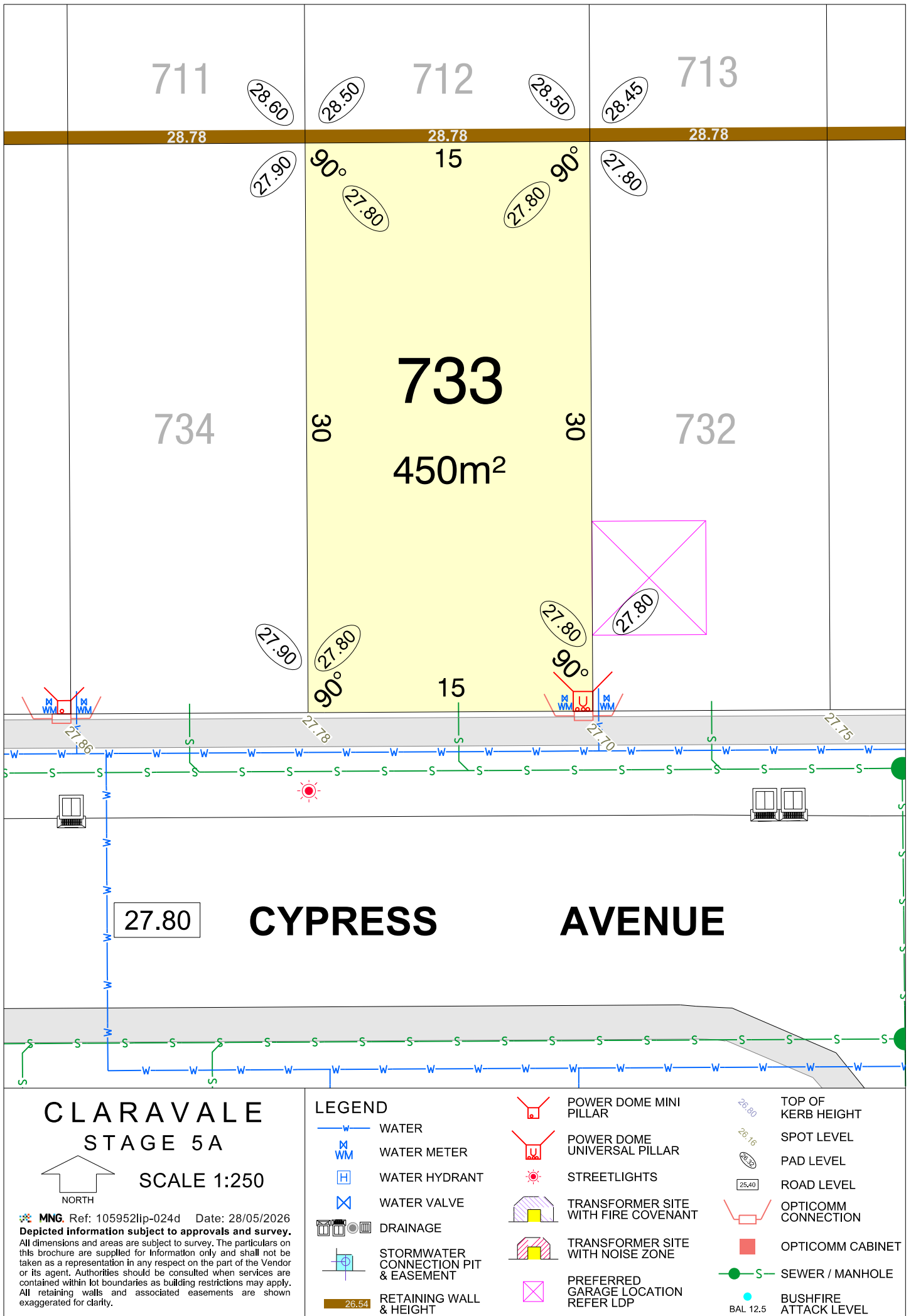

CLARAVALE STAGE 5A

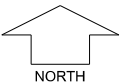

SCALE 1:250

MNG, Ref: 105952lip-024d Date: 28/05/2026
Depicted information subject to approvals and survey.
 All dimensions and areas are subject to survey. The particulars on this brochure are supplied for Information only and shall not be taken as a representation in any respect on the part of the Vendor or its agent. Authorities should be consulted when services are contained within lot boundaries as building restrictions may apply. All retaining walls and associated easements are shown exaggerated for clarity.

LEGEND

- WATER
- WATER METER
- WATER HYDRANT
- WATER VALVE
- DRAINAGE
- STORMWATER CONNECTION PIT & EASEMENT
- RETAINING WALL & HEIGHT
- POWER DOME MINI PILLAR
- POWER DOME UNIVERSAL PILLAR
- STREETLIGHTS
- TRANSFORMER SITE WITH FIRE COVENANT
- TRANSFORMER SITE WITH NOISE ZONE
- PREFERRED GARAGE LOCATION REFER LDP
- TOP OF KERB HEIGHT
- SPOT LEVEL
- PAD LEVEL
- ROAD LEVEL
- OPTICOMM CONNECTION
- OPTICOMM CABINET
- SEWER / MANHOLE
- BUSHFIRE ATTACK LEVEL

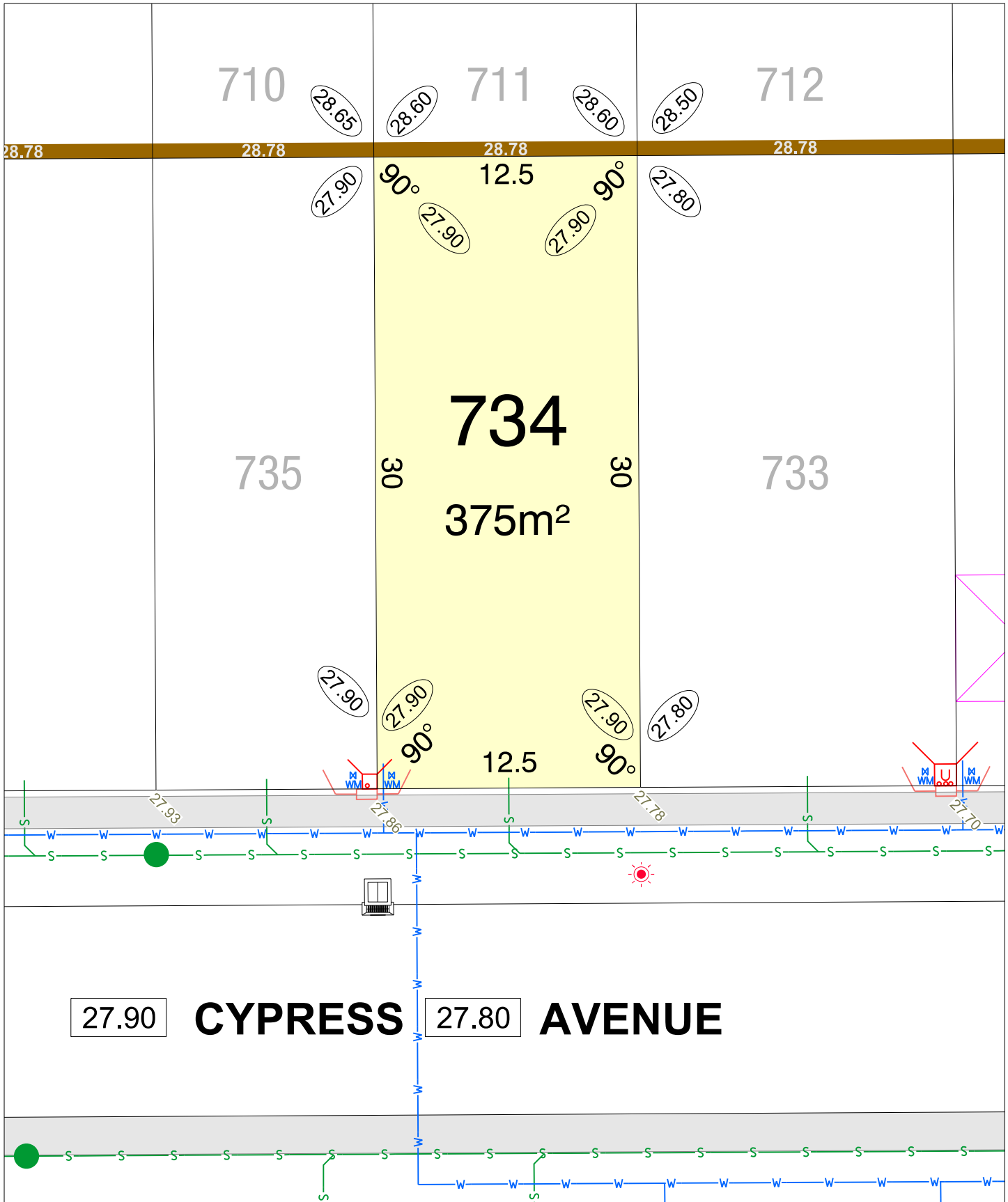

27.90 **CYPRESS** 27.80 **AVENUE**

**CLARAVALE
STAGE 5A**

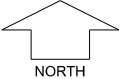

SCALE 1:250

MNG, Ref: 105952lip-024d Date: 28/05/2026
Depicted information subject to approvals and survey.
 All dimensions and areas are subject to survey. The particulars on this brochure are supplied for Information only and shall not be taken as a representation in any respect on the part of the Vendor or its agent. Authorities should be consulted when services are contained within lot boundaries as building restrictions may apply. All retaining walls and associated easements are shown exaggerated for clarity.

LEGEND

- WATER
- WATER METER
- WATER HYDRANT
- WATER VALVE
- DRAINAGE
- STORMWATER CONNECTION PIT & EASEMENT
- RETAINING WALL & HEIGHT
- POWER DOME MINI PILLAR
- POWER DOME UNIVERSAL PILLAR
- STREETLIGHTS
- TRANSFORMER SITE WITH FIRE COVENANT
- TRANSFORMER SITE WITH NOISE ZONE
- PREFERRED GARAGE LOCATION REFER LDP
- TOP OF KERB HEIGHT
- SPOT LEVEL
- PAD LEVEL
- ROAD LEVEL
- OPTICOMM CONNECTION
- OPTICOMM CABINET
- SEWER / MANHOLE
- BUSHFIRE ATTACK LEVEL

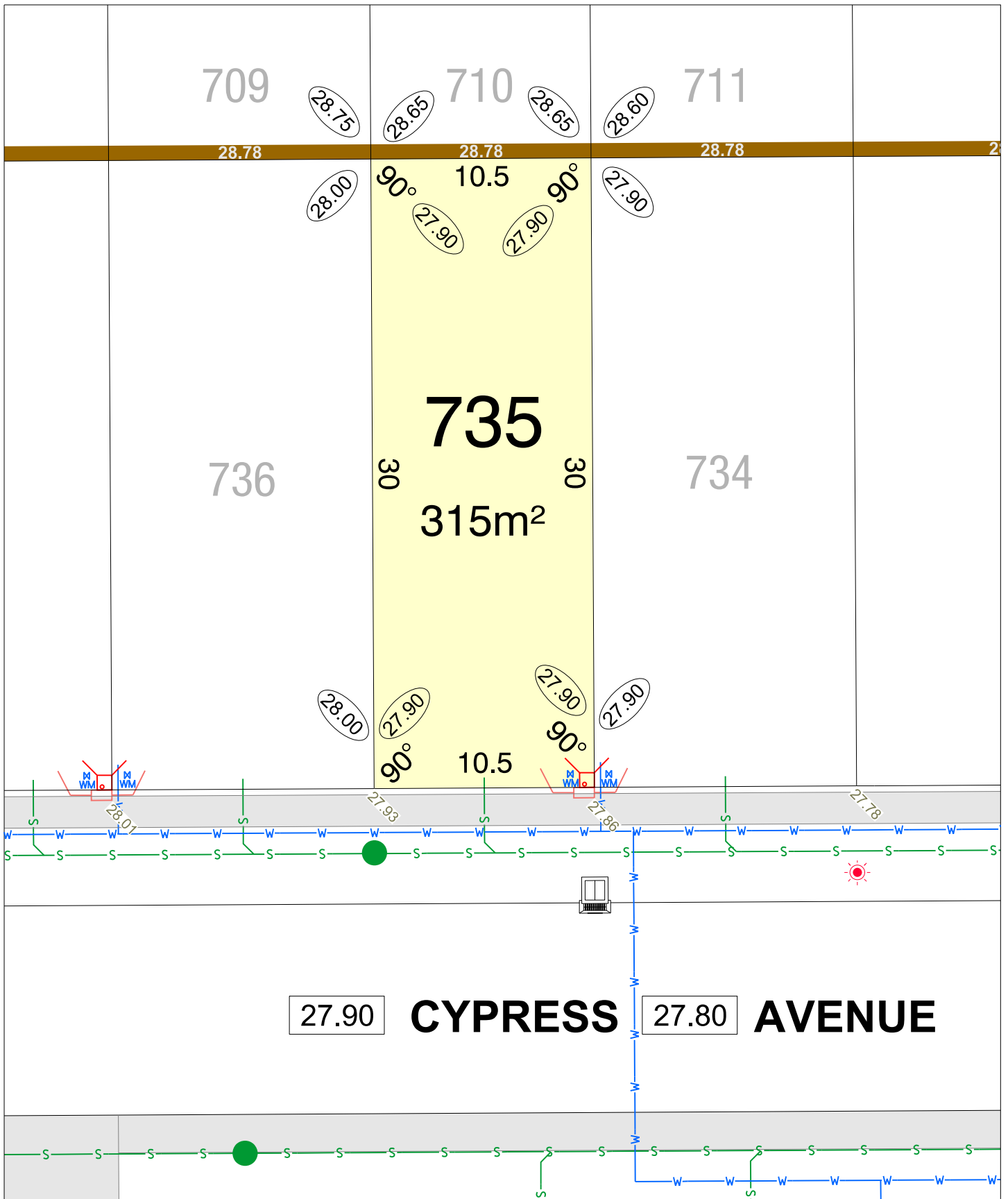

CLARAVALE STAGE 5A

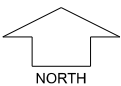

SCALE 1:250

MNG. Ref: 105952lip-024d Date: 28/05/2026
 Depicted information subject to approvals and survey.
 All dimensions and areas are subject to survey. The particulars on this brochure are supplied for Information only and shall not be taken as a representation in any respect on the part of the Vendor or its agent. Authorities should be consulted when services are contained within lot boundaries as building restrictions may apply. All retaining walls and associated easements are shown exaggerated for clarity.

LEGEND

- | | | |
|--------------------------------------|-------------------------------------|-----------------------|
| WATER | POWER DOME MINI PILLAR | TOP OF KERB HEIGHT |
| WATER METER | POWER DOME UNIVERSAL PILLAR | SPOT LEVEL |
| WATER HYDRANT | STREETLIGHTS | PAD LEVEL |
| WATER VALVE | TRANSFORMER SITE WITH FIRE COVENANT | ROAD LEVEL |
| DRAINAGE | TRANSFORMER SITE WITH NOISE ZONE | OPTICOMM CONNECTION |
| STORMWATER CONNECTION PIT & EASEMENT | PREFERRED GARAGE LOCATION REFER LDP | OPTICOMM CABINET |
| RETAINING WALL & HEIGHT | | SEWER / MANHOLE |
| | | BUSHFIRE ATTACK LEVEL |

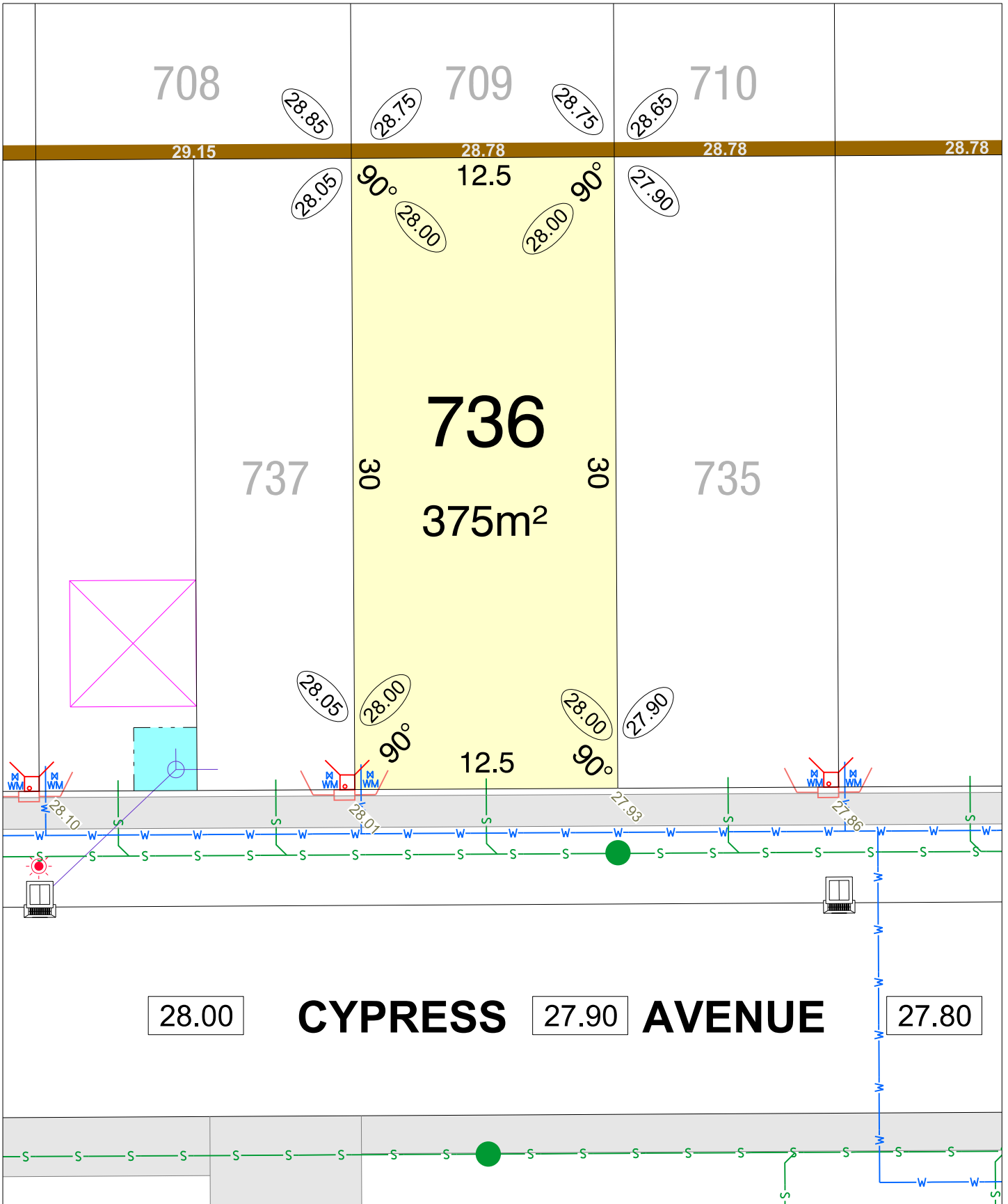

CLARAVALE STAGE 5A

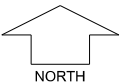

SCALE 1:250

MNG, Ref: 105952lip-024d Date: 28/05/2026
Depicted information subject to approvals and survey.
 All dimensions and areas are subject to survey. The particulars on this brochure are supplied for Information only and shall not be taken as a representation in any respect on the part of the Vendor or its agent. Authorities should be consulted when services are contained within lot boundaries as building restrictions may apply. All retaining walls and associated easements are shown exaggerated for clarity.

LEGEND

- WATER
- WATER METER
- WATER HYDRANT
- WATER VALVE
- DRAINAGE
- STORMWATER CONNECTION PIT & EASEMENT
- RETAINING WALL & HEIGHT
- POWER DOME MINI PILLAR
- POWER DOME UNIVERSAL PILLAR
- STREETLIGHTS
- TRANSFORMER SITE WITH FIRE COVENANT
- TRANSFORMER SITE WITH NOISE ZONE
- PREFERRED GARAGE LOCATION REFER LDP
- SEWER / MANHOLE
- BUSHFIRE ATTACK LEVEL
- TOP OF KERB HEIGHT
- SPOT LEVEL
- PAD LEVEL
- ROAD LEVEL
- OPTICOMM CONNECTION
- OPTICOMM CABINET

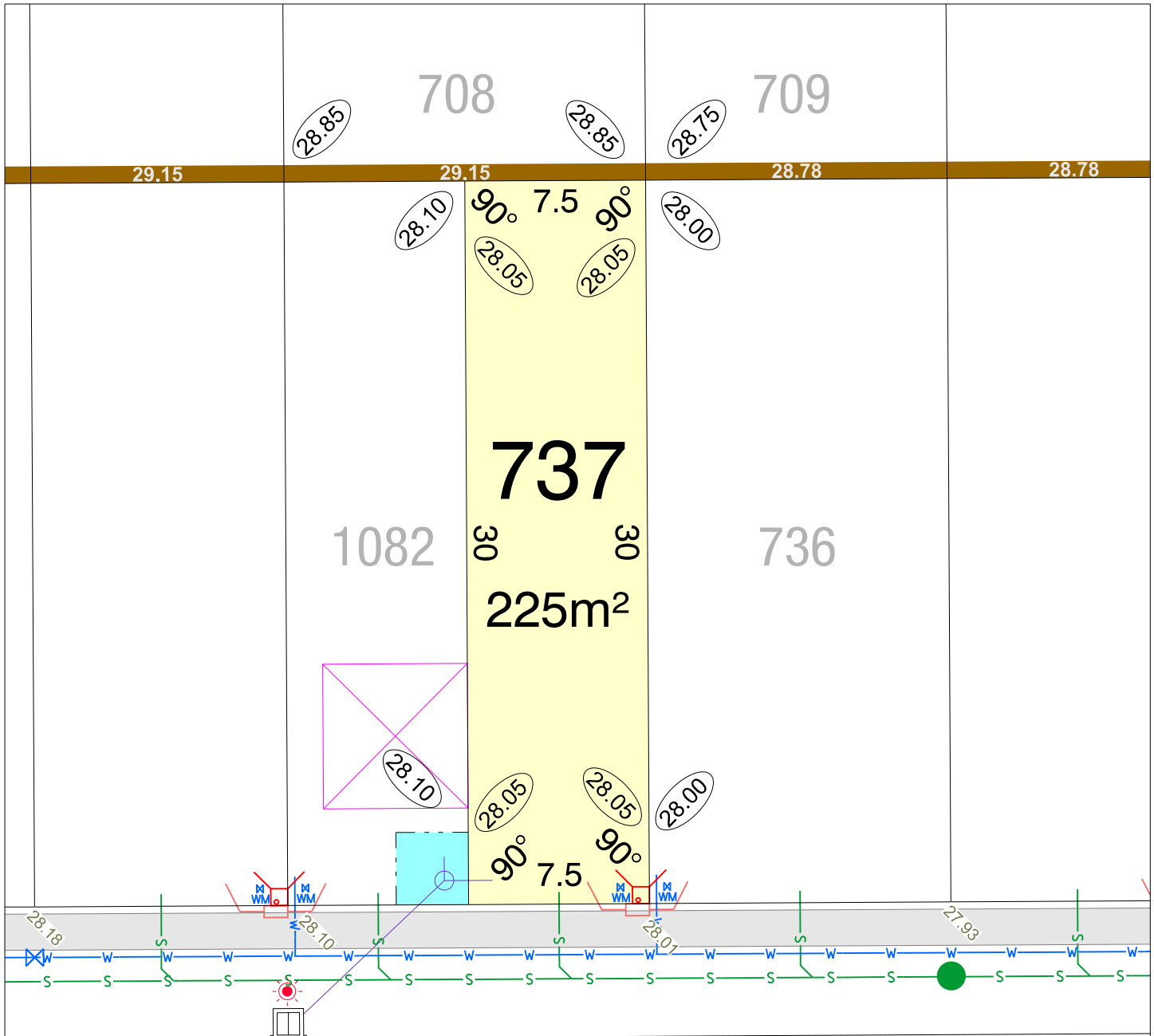

28.10 **CYPRESS** 28.00 **AVENUE** 27.90

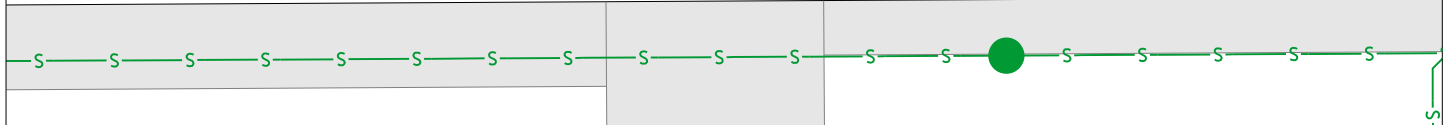



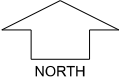

















CLARAVALE STAGE 5A



SCALE 1:250

MNG, Ref: 105952lip-024d Date: 28/05/2026
Depicted information subject to approvals and survey.
 All dimensions and areas are subject to survey. The particulars on this brochure are supplied for Information only and shall not be taken as a representation in any respect on the part of the Vendor or its agent. Authorities should be consulted when services are contained within lot boundaries as building restrictions may apply. All retaining walls and associated easements are shown exaggerated for clarity.

LEGEND

- | | | | | | |
|-------------------------------------------------------------------------------------|--------------------------------------|-------------------------------------------------------------------------------------|-------------------------------------|---------------------------------------------------------------------------------------|-----------------------|
|  | WATER |  | POWER DOME MINI PILLAR |  | TOP OF KERB HEIGHT |
|  | WATER METER |  | POWER DOME UNIVERSAL PILLAR |  | SPOT LEVEL |
|  | WATER HYDRANT |  | STREETLIGHTS |  | PAD LEVEL |
|  | WATER VALVE |  | TRANSFORMER SITE WITH FIRE COVENANT |  | ROAD LEVEL |
|  | DRAINAGE |  | TRANSFORMER SITE WITH NOISE ZONE |  | OPTICOMM CONNECTION |
|  | STORMWATER CONNECTION PIT & EASEMENT |  | PREFERRED GARAGE LOCATION REFER LDP |  | OPTICOMM CABINET |
|  | RETAINING WALL & HEIGHT | | |  | SEWER / MANHOLE |
| | | | |  | BUSHFIRE ATTACK LEVEL |

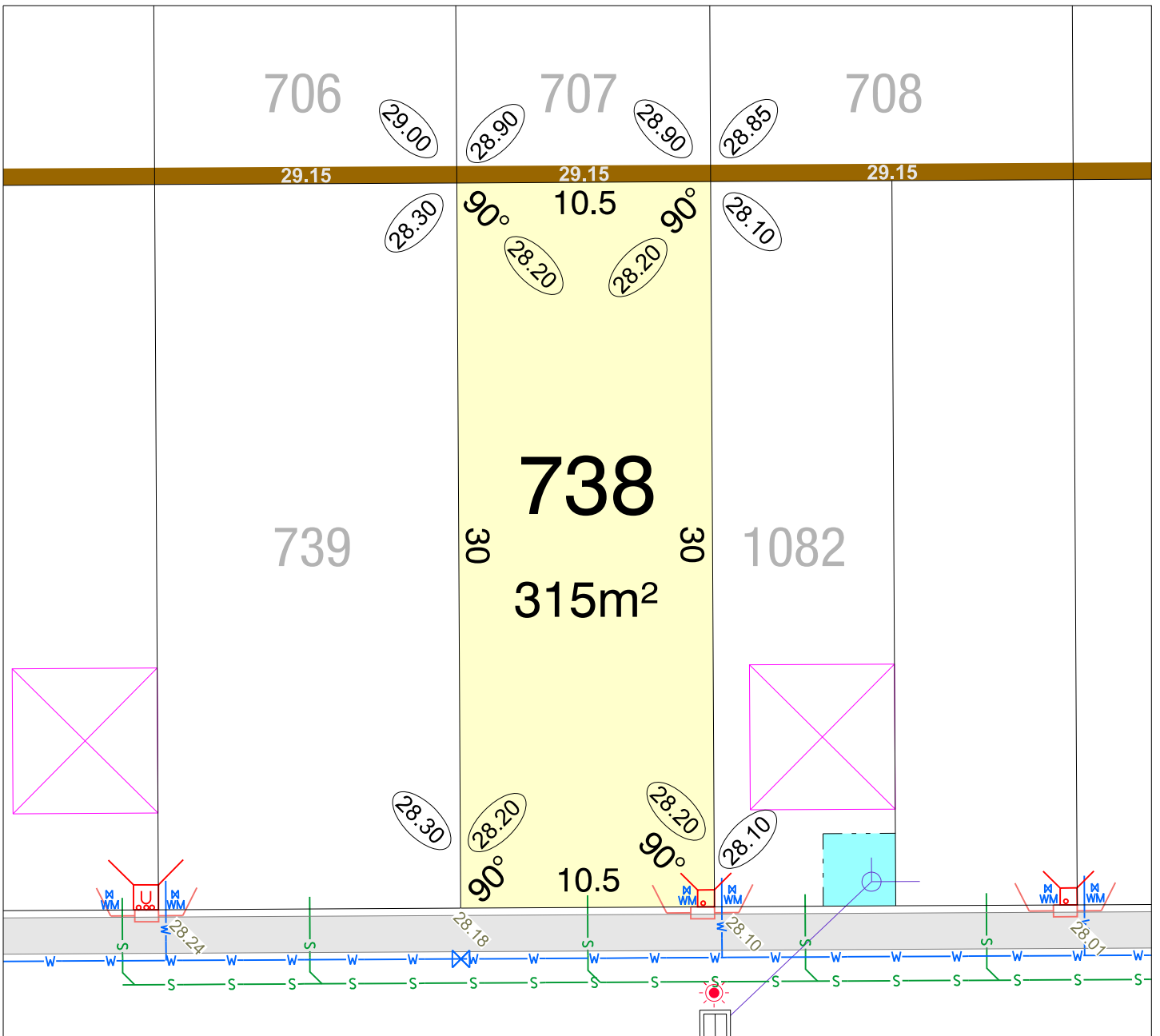

28.20 **CYPRESS** 28.10 **AVENUE** 28.00

CLARAVALE STAGE 5A

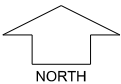

SCALE 1:250

MNG, Ref: 105952lip-024d Date: 28/05/2026
Depicted information subject to approvals and survey.
 All dimensions and areas are subject to survey. The particulars on this brochure are supplied for Information only and shall not be taken as a representation in any respect on the part of the Vendor or its agent. Authorities should be consulted when services are contained within lot boundaries as building restrictions may apply. All retaining walls and associated easements are shown exaggerated for clarity.

LEGEND

- | | | |
|--------------------------------------|-------------------------------------|-----------------------|
| WATER | POWER DOME MINI PILLAR | TOP OF KERB HEIGHT |
| WATER METER | POWER DOME UNIVERSAL PILLAR | SPOT LEVEL |
| WATER HYDRANT | STREETLIGHTS | PAD LEVEL |
| WATER VALVE | TRANSFORMER SITE WITH FIRE COVENANT | ROAD LEVEL |
| DRAINAGE | TRANSFORMER SITE WITH NOISE ZONE | OPTICOMM CONNECTION |
| STORMWATER CONNECTION PIT & EASEMENT | PREFERRED GARAGE LOCATION REFER LDP | OPTICOMM CABINET |
| RETAINING WALL & HEIGHT | | SEWER / MANHOLE |
| | | BUSHFIRE ATTACK LEVEL |

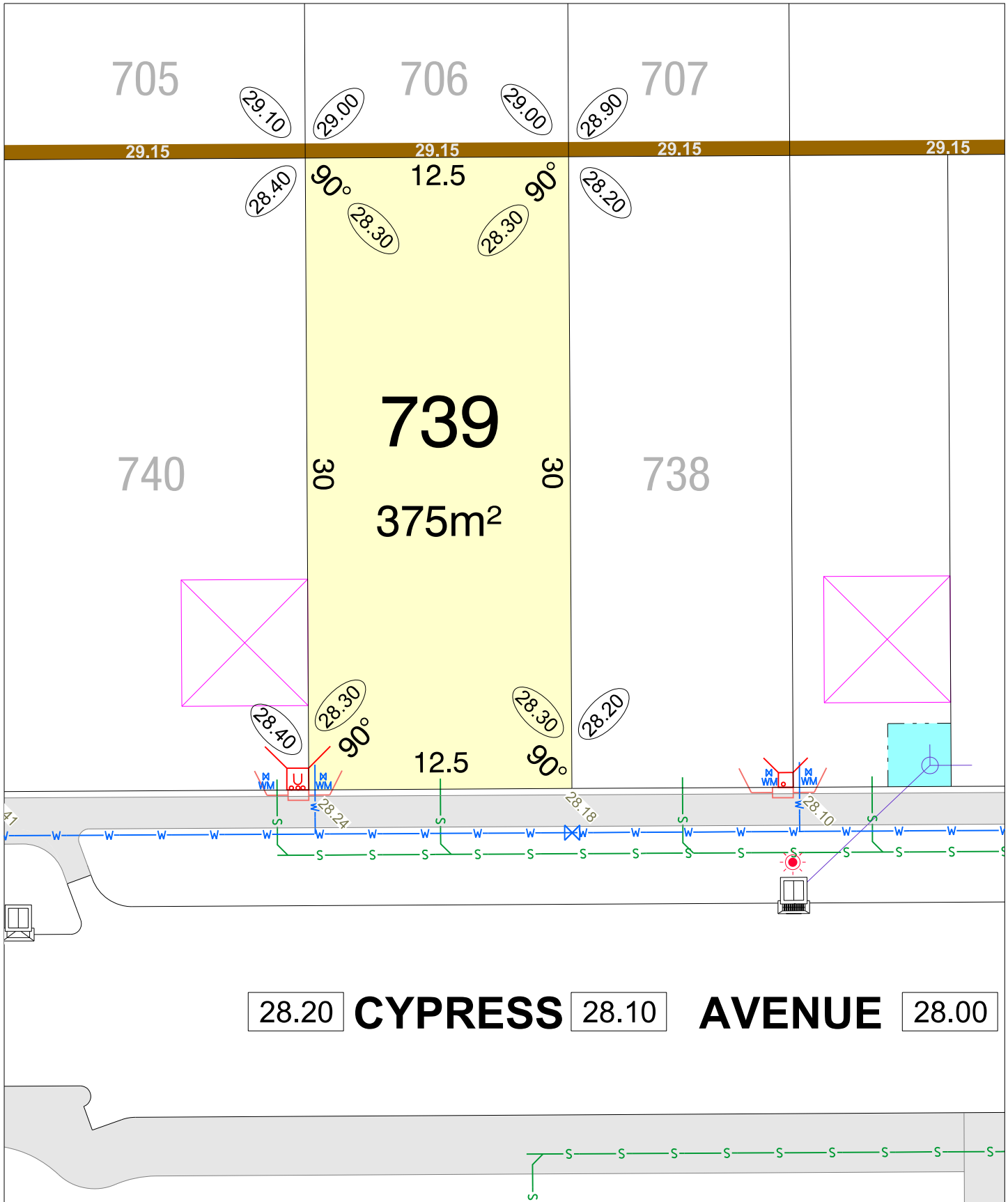

28.20 **CYPRESS** 28.10 **AVENUE** 28.00

CLARAVALE STAGE 5A

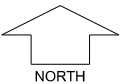

SCALE 1:250

MNG, Ref: 105952lip-024d Date: 28/05/2026
Depicted information subject to approvals and survey.
 All dimensions and areas are subject to survey. The particulars on this brochure are supplied for Information only and shall not be taken as a representation in any respect on the part of the Vendor or its agent. Authorities should be consulted when services are contained within lot boundaries as building restrictions may apply. All retaining walls and associated easements are shown exaggerated for clarity.

LEGEND

- | | | |
|--------------------------------------|-------------------------------------|-----------------------|
| WATER | POWER DOME MINI PILLAR | TOP OF KERB HEIGHT |
| WATER METER | POWER DOME UNIVERSAL PILLAR | SPOT LEVEL |
| WATER HYDRANT | STREETLIGHTS | PAD LEVEL |
| WATER VALVE | TRANSFORMER SITE WITH FIRE COVENANT | ROAD LEVEL |
| DRAINAGE | TRANSFORMER SITE WITH NOISE ZONE | OPTICOMM CONNECTION |
| STORMWATER CONNECTION PIT & EASEMENT | PREFERRED GARAGE LOCATION REFER LDP | OPTICOMM CABINET |
| RETAINING WALL & HEIGHT | | SEWER / MANHOLE |
| | | BUSHFIRE ATTACK LEVEL |

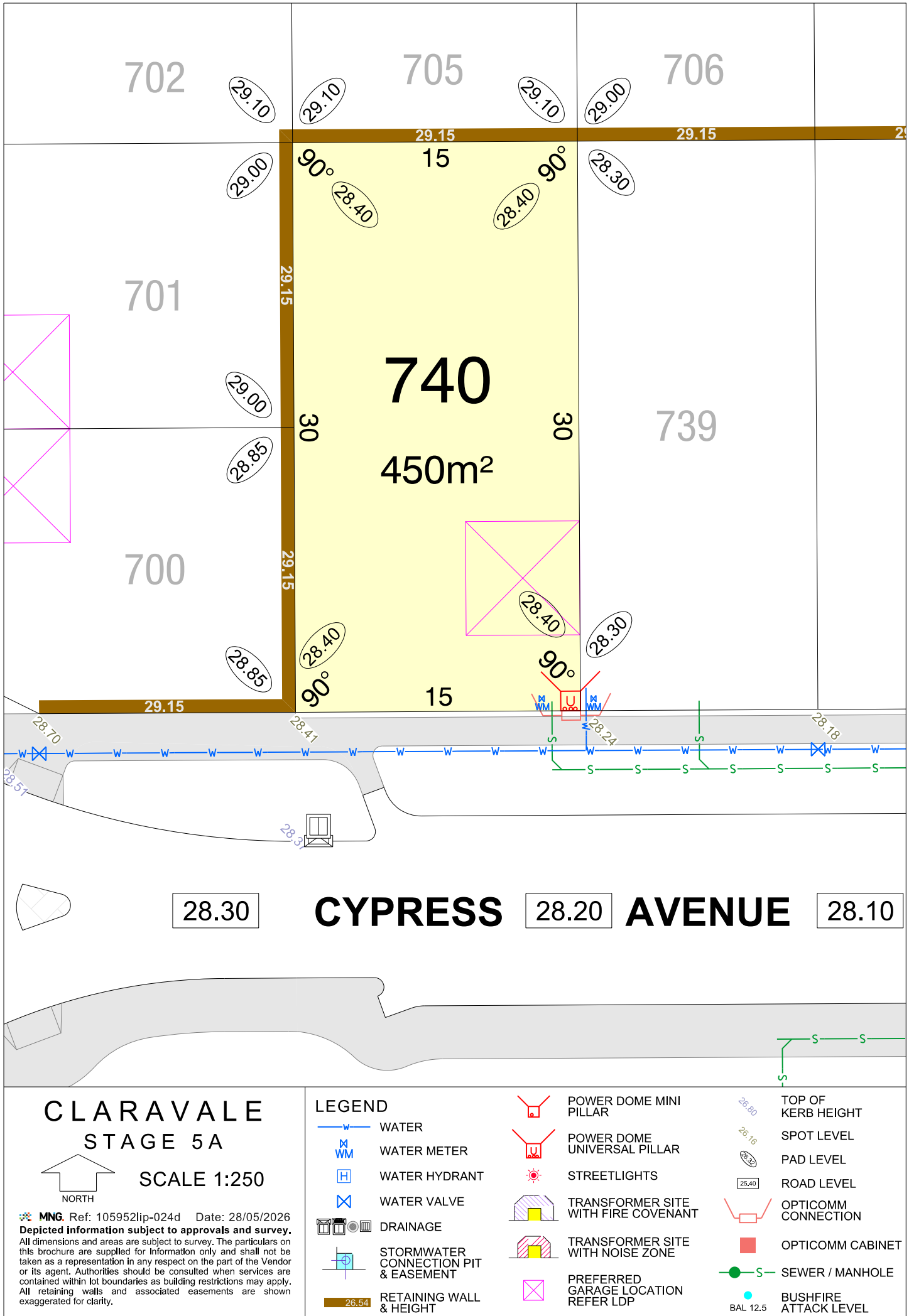

CLARAVALE STAGE 5A

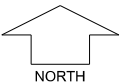

SCALE 1:250

MNG, Ref: 105952lip-024d Date: 28/05/2026
Depicted information subject to approvals and survey.
 All dimensions and areas are subject to survey. The particulars on this brochure are supplied for Information only and shall not be taken as a representation in any respect on the part of the Vendor or its agent. Authorities should be consulted when services are contained within lot boundaries as building restrictions may apply. All retaining walls and associated easements are shown exaggerated for clarity.

LEGEND

- WATER
- WATER METER
- WATER HYDRANT
- WATER VALVE
- DRAINAGE
- STORMWATER CONNECTION PIT & EASEMENT
- RETAINING WALL & HEIGHT
- POWER DOME MINI PILLAR
- POWER DOME UNIVERSAL PILLAR
- STREETLIGHTS
- TRANSFORMER SITE WITH FIRE COVENANT
- TRANSFORMER SITE WITH NOISE ZONE
- PREFERRED GARAGE LOCATION REFER LDP
- TOP OF KERB HEIGHT
- SPOT LEVEL
- PAD LEVEL
- ROAD LEVEL
- OPTICOMM CONNECTION
- OPTICOMM CABINET
- SEWER / MANHOLE
- BUSHFIRE ATTACK LEVEL

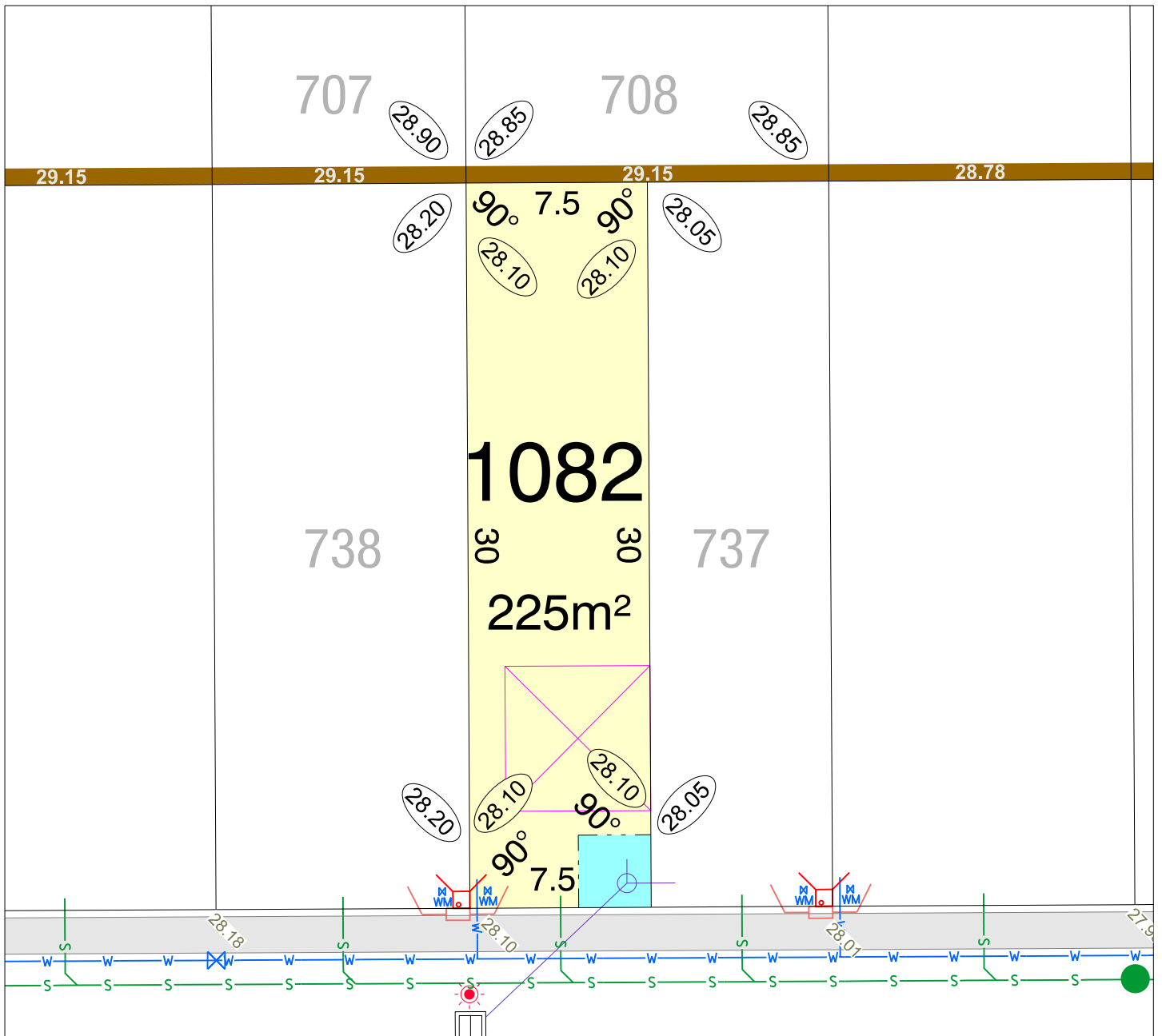

28.10 **CYPRESS** 28.00 **AVENUE** 27.90

CLARAVALE STAGE 5A

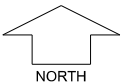

SCALE 1:250

MNG, Ref: 105952lip-024d Date: 28/05/2026
Depicted information subject to approvals and survey.
 All dimensions and areas are subject to survey. The particulars on this brochure are supplied for Information only and shall not be taken as a representation in any respect on the part of the Vendor or its agent. Authorities should be consulted when services are contained within lot boundaries as building restrictions may apply. All retaining walls and associated easements are shown exaggerated for clarity.

LEGEND

- WATER
- WATER METER
- WATER HYDRANT
- WATER VALVE
- DRAINAGE
- STORMWATER CONNECTION PIT & EASEMENT
- RETAINING WALL & HEIGHT

- POWER DOME MINI PILLAR
- POWER DOME UNIVERSAL PILLAR
- STREETLIGHTS
- TRANSFORMER SITE WITH FIRE COVENANT
- TRANSFORMER SITE WITH NOISE ZONE
- PREFERRED GARAGE LOCATION REFER LDP
- TOP OF KERB HEIGHT
- SPOT LEVEL
- PAD LEVEL
- ROAD LEVEL
- OPTICOMM CONNECTION
- OPTICOMM CABINET
- SEWER / MANHOLE
- BUSHFIRE ATTACK LEVEL